

Momentarily-Energized Pilot Valves for Irrigation Systems

A. S. Humpherys, R. S. Pauliukonis

MEMBER
ASAE

ABSTRACT

MOMENTARILY-ENERGIZED solenoid valves were developed in both 3- and 4-way configurations. The 3-way model is used as a pilot valve primarily for water-operated valves in surface irrigation systems. The 4-way model can be used with pneumatic operators such as air cylinders. The valves are powered by capacitor discharge with energy supplied from batteries and do not require continuous energization to maintain valve position.

INTRODUCTION

Surface irrigation must be automated to reduce its labor requirement if it is to remain attractive to irrigators. Pipelines are used increasingly to improve farm irrigation systems and these can be automated by using valves to sequence water application from one set to another. Gated pipe on the surface of the ground is commonly used to distribute irrigation water to individual furrows. Automated valves which use water from the pipeline for operation (Humpherys and Stacey, 1975) are now commercially available.* However, a low cost, 3-way pilot valve is needed for use with the irrigation valves.

Timer-controlled pilot valves are used to control the flow of water to-and-from a bladder inside the automated irrigation valve. The irrigation valve closes when water from the pipeline fills the bladder and it opens when water is exhausted from the bladder as shown in Fig. 1. The pilot valve most commonly used during the irrigation valve development stage was a 3-way plug or ball valve driven by a ladder chain from a small DC electric motor. These valves were used because their relatively large ports, 10 mm (3/8 in.), provided the necessary flow capacity and they could be powered by batteries. However, because of the labor required, they were costly to assemble and sometime malfunctioned in the field. Continuously-energized, solenoid-operated pilot valves were tested, but they had small ports, 4 mm (11/64 in.) or smaller. Thus, the irrigation valve

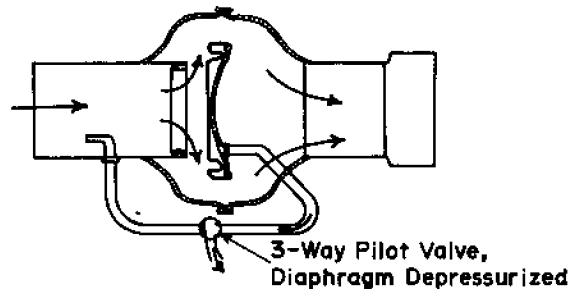

IRRIGATION VALVE OPEN

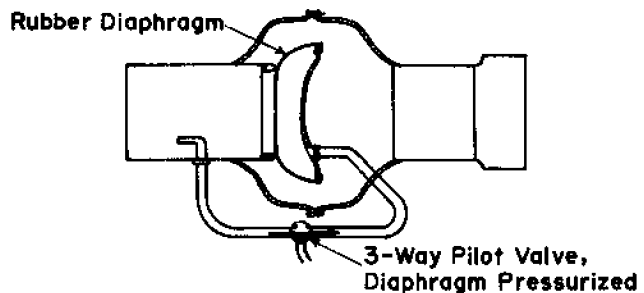

IRRIGATION VALVE CLOSED

Fig. 1—Schematic views of a water-operated valve.

response time was too slow because of the time required to pass water to-and-from the bladder. The small ports were also subject to plugging by foreign particles which are sometimes present in the irrigation water.

Continuously-energized pilot valves can be used only to a limited extent because electrical power is seldom available at field sites where surface irrigation valves are used. Therefore, the pilot valves must be battery-powered and these are usually dual-coil, momentarily-energized, spool or latching type valves.

An extensive search was made to locate a commercially available pilot valve for this application. However, a satisfactory low cost valve could not be found. Three-way valves that were available either had (a) orifices that were too small for water flow, or (b) were continuously energized, and, thus, could not be powered by batteries, or (c) required 35 to 70 kpa (5 to 10 psi) minimum operating pressure, or (d) a combination of these factors. Some valves which had sufficient flow capacity were internally piloted and required a minimum operating pressure either to operate the internal pilot, or to form an effective seal, or both. The minimum operating pressure was greater than that normally available since many automated surface systems are supplied by water from canals and ditches where the pressure head is usually limited.

Article was submitted for publication in February, 1983; reviewed and approved for publication by the Soil and Water Div. of ASAE in April, 1983.

Joint contribution from the USDA Agricultural Research Service, Kimberly, ID, and Patentrol Co., Cleveland, OH.

Company and trade names are shown for the benefit of the reader and do not imply endorsement or preferential treatment of the company or products noted.

The authors are: ALLAN S. HUMPHERYS, Agricultural Engineer, Snake River Conservation Research Center, Kimberly, ID; RICHARD S. PAULIUKONIS, President, Patentrol Co., Cleveland, OH.

Acknowledgment: The authors gratefully acknowledge the assistance provided by Robert L. Stacey and Michael Wilson, Engineering Technicians at the Snake River Conservation Research Center, in making laboratory tests with the solenoid valves.

*Hastings Irrigation Pipe Co., Hastings, NE.

In summary, a 3-way pilot valve for use with water-operated irrigation valves needs to (a) have relatively large ports, 8 mm (5/16 in.) or larger, (b) be operable from battery power, (c) be water tight at pressures in the range from 2 to 70 kpa (0.3 to 10 psi), and (d) be satisfactory for outdoor field use.

Since a valve to satisfy these criteria was not available, a new solenoid valve was developed. The objective of this paper is to describe this valve and to present information regarding its physical description, operational characteristics, and field tests.

VALVE DEVELOPMENT

A valve with a sliding arbor or spool was chosen because this type of valve basically can be made to satisfy the requirements. The first prototype models either leaked or required too much force to shift positions. Because of the low shifting force required for a battery-powered valve and the low operating pressure requirement, the normal tolerance and other construction specifications for this type valve were not entirely applicable. It was necessary to use seals that seal at very low pressures and yet do not fit so tightly as to cause excessive shifting force. Valve models with different combinations of O-ring and U-cup seals, each having a different formulation and hardness, were tested during the valve development process. The seals in some of the earlier models sometimes stuck slightly inside the valve body during extended periods of nonuse. However, 3-way valves of the final design exhibited zero leakage and readily shifted when subjected to water pressures from zero to 54 kpa (8 psi) with time periods exceeding three months between operations.

Different solenoid operators were also tested. A production model encapsulated solenoid operator was modified for this application. This intermittent-duty, low resistance solenoid was made initially with 1.5 ohm coils, however, 0.6 ohm units, which have a greater force, were developed for the final valve design.

VALVE DESCRIPTION

The final valve design is shown schematically in Fig. 2. The valve body is constructed from 32 mm (1-1/4 in.) hexagonal brass or anodized aluminum bar stock and has three threaded ports, approximately 13 mm (1/2 in. NPT) diameter, with 8 mm (5/16 in.) diameter orifice openings. The spool inside the valve housing is shifted longitudinally directly by a solenoid operator located at each end of the spool. The center or common port, No. 1, is in communication with either port 2 or port 3. When the spool is shifted by an electrical pulse to the operator, the port to which the common port is connected is reversed. Since ports 2 and 3 are identical, they are not individually designated and can be used interchangeably.

The 8 mm (5/16 in.) diameter spool is made from 446 stainless steel which has the necessary magnetic properties and is more corrosion resistant than the 416 stainless steel used in the earlier models. The spool is recessed in its central portion and has an O-ring seal on each side of the recess as shown in Figs. 2 and 3. This unique design provides a relatively large flow area and minimizes spool travel since the O-ring does not have to slide across the center or common port when the spool position is shifted. The shifting force requirement is

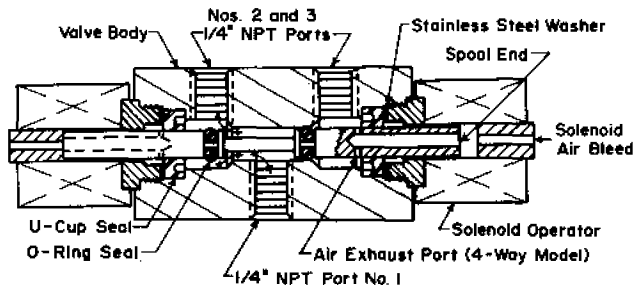

Fig. 2—Cross-section view of a spool type solenoid-operated pilot valve.

thereby reduced from that in conventional spool designs, because the extra friction drag associated with O-ring travel across the center port is eliminated. Minimizing spool travel also increases the effective shifting force available from a given solenoid. The force-versus-stroke relationship for an electric solenoid is typically hyperbolic, such that its output force decreases exponentially with stroke length. Thus, since the force is not equal along the entire length of travel, a high average force is developed over a shorter travel distance. Therefore, the shorter the travel distance, the smaller the solenoid can be to provide the required shifting force.

The outer ends of the spool are sealed with U-cups which are stationary in the valve body. Thus, instead of U-cups traveling with the spool in the conventional manner, they remain stationary and the spool ends slide inside the U-cups. This feature further reduces the required shifting force since the sliding friction occurs around a smaller circumference than if the U-cup traveled with the spool. U-cups were chosen for the end seals in preference to O-rings because they (a) require less squeeze when installed, (b) seal at lower pressures, and (c) require less breakaway force.

The valve body or housing is tapped on each end with 19 mm (3/4 in. x 20) diameter threads to accommodate threaded solenoid operators. The potted-coil, intermittent-duty solenoids can be operated with momentary voltages of 24 V or greater. Nominal 24 VDC in the field was supplied by 22 1/2-V dry cell batteries. Since the valve is a momentarily-energized type, the voltage need only be applied momentarily for a position change; continuous energization is not required to maintain valve position. This is a primary advantage since a momentarily applied voltage can be supplied from a battery and capacitor. Continuous-duty operators with voltage ratings of 24 or 115 V may also be used. The spool ends extend into the operator cavity and serve as the solenoid armature. Each operator has a 1.2 mm (0.047 in.) air-bleed hole in its end.

The valve is also made in a 4-way configuration for use with air. This model uses a spool with its ends drilled to provide a passageway for air exhaust as shown in Fig. 2. Air is then exhausted through the air bleeds in the solenoid operators.

OPERATION

Small valves are conventionally rated with a C, flow coefficient which is defined as the quantity of 16 °C (60 °F) water, expressed in gallons per minute (gpm), which will flow through a valve with a differential pressure of 1 psi (70.32 cm or 27.68 in. of water head). Laboratory tests were conducted with water to determine the

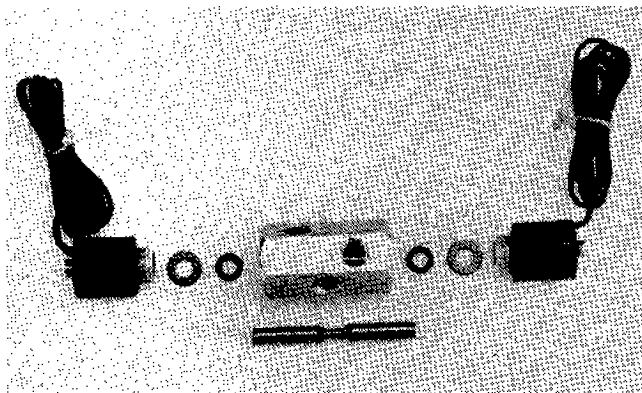

Fig. 3—Exploded view of a momentarily-energized solenoid valve.

solenoid valve's C_v value. Replicated tests were made on three different valves with flow directed through each orifice. The pressure head-discharge relationship is shown in Fig. 4 and can be expressed as

$$Q = CH^n$$

where

Q = water flow discharge, L/S when H is in cm; GPM when H is in inches

C = discharge coefficient = 0.0091 when H is in cm and 0.235 when H is in inches

H = water pressure, cm (in.)

n = 0.522

The C_v coefficient for this valve determined from Fig. 4 and adjusted to a temperature of 16 °C (60 °F) is 1.3. The adjustment for temperature was made with the relation

$$C_v = \frac{C_v'}{f_T}$$

where

C_v = adjusted flow coefficient

C_v' = flow coefficient determined with water at a temperature other than 16 °C (60 °F)

$$f_T = \left[\frac{530}{460 + T} \right]^{0.5}$$

T = water temperature in °F at which C_v was determined.

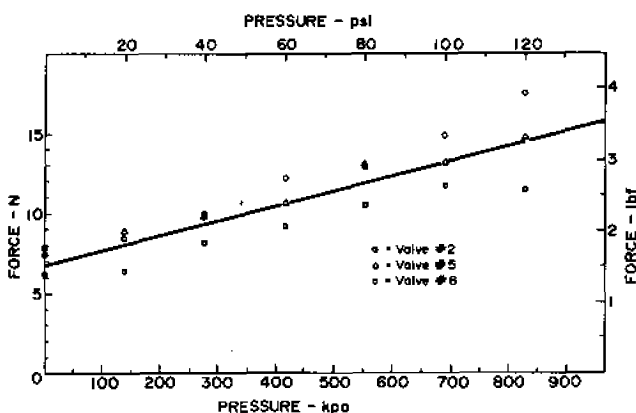

Fig. 5—Relative effect of operating pressure on solenoid valve shifting force requirement. (The shifting force was determined at a pressurized elapsed time of three minutes between shifting operation.)

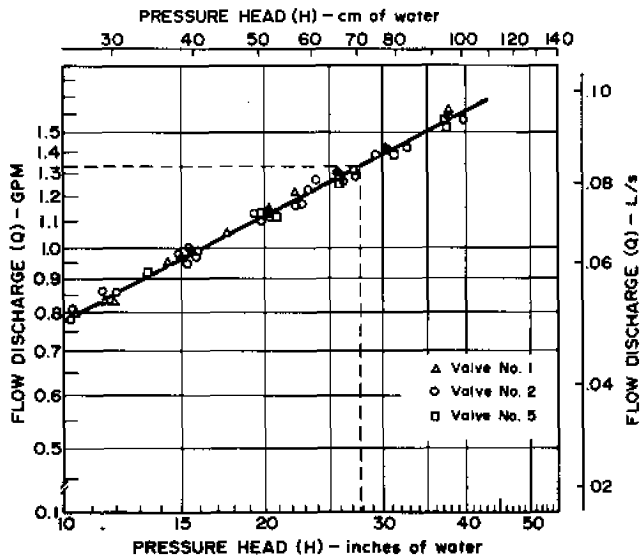

Fig. 4—Solenoid valve head-discharge relationship for water.

The force required to shift the valve spool varies with both operating pressure and elapsed time from the previous operation. Tests were conducted to determine the relative magnitude of these variations. In actual operation, the valve spool is shifted from one position to the next in a fraction of a second. Since it was not possible to measure the actual shifting force under these conditions, this action was simulated by mounting the valve in a metal lathe and manually shifting it with a single "pulse" type force applied very quickly with the lathe carriage and a spring dial gauge. The shifting force applied in this manner demonstrated qualitatively the relative effects of pressure and elapsed time that were observed in actual valve use. The data presented in Fig. 5 for three valves show that the shifting force increases with pressure in approximately a linear relationship. The data points represent mean replicated test values for each valve with a pressurized elapsed time of three minutes from the previous operation. Variations that can be expected for different valves and operating conditions can also be noted on the plot. Values for other new and used valves generally fell within the range shown. Valve 2 was a 4-way valve that had been used with air for one year in the field without being reconditioned before the test. Valve 5 was a 3-way valve that had been used with

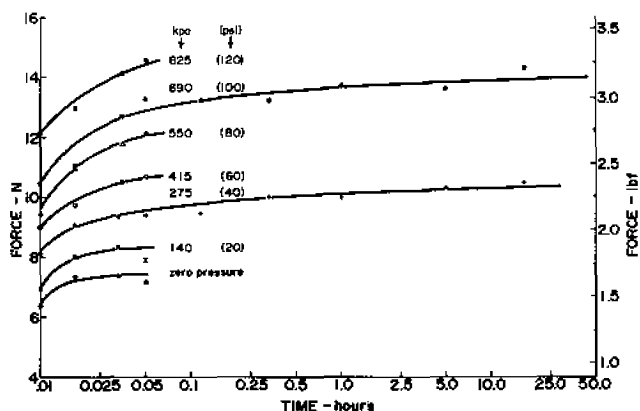
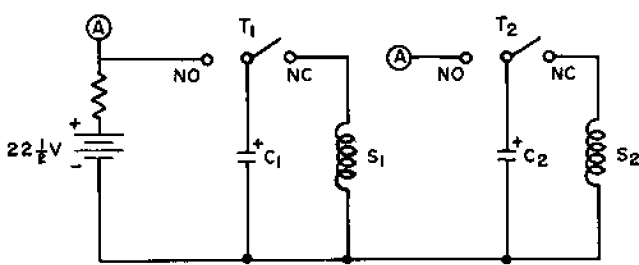

Fig. 6—Relative effect of elapsed time between operations on solenoid valve shifting force requirement.



Circuit diagram for a single irrigation valve

T = Timer/Switch

S₁, S₂ Open/Close Solenoids for Valve 1

S₃, S₄ Open/Close Solenoids for Valve 2

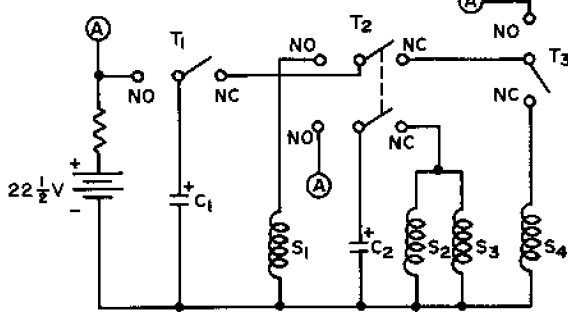

Circuit diagram for twin irrigation valves

Fig. 7—Electrical diagrams illustrating the use of a battery and capacitor to operate pilot valve solenoids for both single and twin irrigation valves.

water in the field for one year. It was cleaned and lubricated before the test. Valve 6 was a factory-new 3-way valve.

The relative effect of elapsed time on the shifting force is shown in Fig. 6. The practical effect of elapsed time is insignificant since over 95% of the increased shifting force requirement occurs within the first hour following the previous valve shifting operation. In actual use, most elapsed time periods between valve operations exceed one hour. Therefore, time periods of several days or even weeks between irrigation valve use should not affect the pilot valve's operation. Additional tests made at the end of 7- and 14-day time periods verified this conclusion. The measured peak momentarily applied force available from a solenoid operator powered by an 18,000 μ fd capacitor charged to 22 V, was about 15 to 18 N (3.5 to 4 lbf).

An 18,000 μ fd capacitor, charged from a 22 1/2-V battery, was used to provide the momentary electrical pulse needed to shift each single valve. The diagram shown in Fig. 7 illustrates the electric circuit used to actuate solenoid operators on pilot valves used with both single and twin irrigation valves. Either electronic or mechanical timers were used for the timer/switches shown in the diagrams.

Potted-coil solenoid operators having different voltage ratings and resistances are interchangeable on the same valve. The inrush current of the electrical pulse to intermittent duty operators is very high. Thus, for momentarily-energized applications, a controller's load driving components must have a minimum electrical current rating of about 10-12 amps.

The 3-way pilot valves were used primarily with water-operated surface irrigation valves. They direct water from the pipeline through port No. 2 to common port

No. 1 to fill or pressurize the irrigation valve's bladder or diaphragm (Fig. 1) to close the irrigation valve. When the pilot valve shifts, port No. 1 is in communication with exhaust port No. 3 and the irrigation valve bladder is emptied to open the valve.

The 4-way valve model, designed for use with air, can be used as a pilot for double-acting pneumatic operators such as air cylinders. The valve is rated for use at pressures up to 1000 kpa (150 psi). However, since the force required to shift the valve increases with operating pressure as shown in Fig. 5, the air pressure was regulated to approximately 500 kpa (75 psi) or less.

Thermal-related dimensional changes for the temperature range to which the valve will normally be subjected are minimal. The bore diameter size variation for a 56 °C (100 °F) temperature change is only 0.01 mm (0.00046 in.) for aluminum which is less than the allowable construction tolerances.

FIELD TESTS

Ten 3-way pilot valves were field tested during two summers with water-operated irrigation valves as shown in Fig. 8. The pilot valves were subjected to water pressures in the 3 to 70 kpa (0.4 to 10 psi) range with time intervals of up to two weeks between valve operations. None of the pilot valves leaked during this testing period and none of them failed to shift because of sticking seals. Valves which had been used during the summer and stored "dry" during the non-irrigating season, shifted when bench tested after three months of nonuse.

Sediment from the irrigation water occasionally accumulated in some valves and prevented them from shifting. The valve can tolerate some sediment, however, in these cases, the spool cavity was completely filled with sediment. This problem was remedied by installing a small reservoir in the water supply line to the pilot valve to allow sediment to settle before entering the valve.

When the pilot valves were inspected at the end of the second irrigation season, the aluminum valve bodies were slightly corroded. One pilot valve, having a brass body for comparative testing, was not corroded. The irrigation water to which the valves were subjected was diverted from the Snake River and had a relatively low salt content (approximately 500 micromhos). When the valves are to be used with irrigation water which has a moderate to high chloride, bicarbonate or total salt

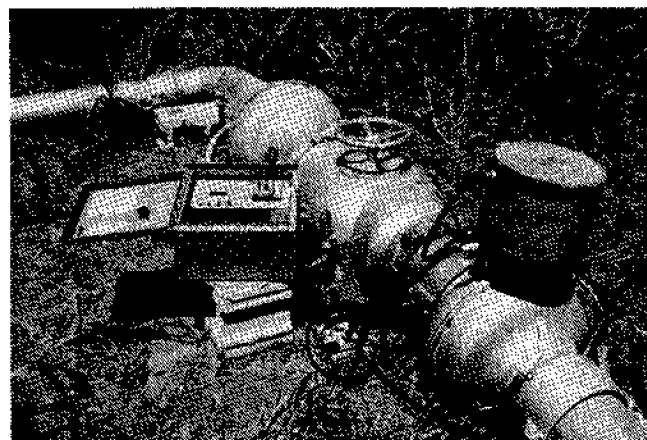

Fig. 8—Three-way pilot valve being used with a water-operated surface irrigation valve.

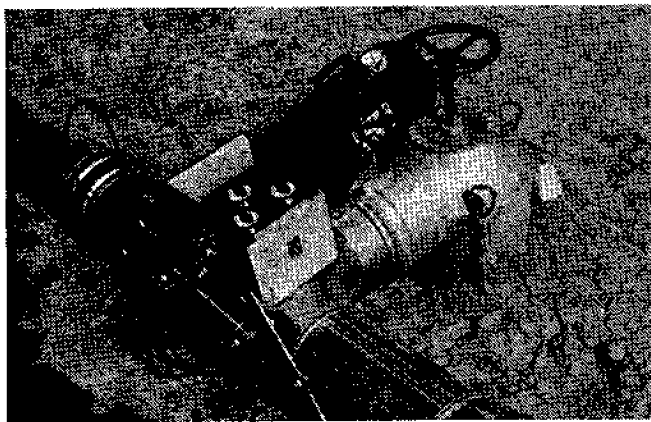

Fig. 9—Four-way pilot valves being used with air-operated irrigation butterfly valves.

content, such as that from some wells, then brass bodies should be used.

Insects built nests in the small air-bleed holes at the outer ends of some solenoids. With these plugged, air could not readily escape from the operator's interior cavity when the valves were shifted. This problem was solved by attaching stainless steel muffler/filter† in the bleed ports which are tapped with No. 18 (3/16 in.) NF threads. The filters also prevent dust and foreign particles from entering the exhaust openings.

Four-way pilot valves were field tested with irrigation butterfly valves operated by air cylinders such as those shown in Fig. 9. The 27 L (7 gal) portable air tanks, used to provide air pressure for valve operation, maintained their pressure between irrigations which indicated that the pilot valves were air tight. Problems were experienced during earlier field tests when some pilot valves failed to

†Clippard Instrument Laboratory, Inc., Cincinnati, OH.

shift at tank pressures above approximately 600 kpa (90 psi). This was corrected in subsequent tests by installing a pressure regulator on each tank to limit the operating pressure to approximately 500 kpa (75 psi) or less.

The valves are now commercially available.‡ When used with water, the valves should be cleaned and lubricated each year.

SUMMARY

A momentarily-energized solenoid valve was developed for use as a pilot for automated irrigation valves. This is a spool type valve which (a) has relatively large ports, 8 mm (5/16 in.) diameter, to permit rapid filling and emptying of water-filled irrigation valve bladders, (b) can be operated from battery power, (c) does not leak when used at low water pressure in the range from 2 to 70 kpa (0.3 to 10 psi) and (d) is environmentally satisfactory for field use. The valve is made in a 3-way configuration for use primarily with water-operated valves and in a 4-way model for use in pneumatic applications.

The valve is made from hexagonal brass or anodized aluminum bar stock with a stainless steel spool that is shifted longitudinally by solenoid operators located at each end. It has a C_v value of 1.3 and can be equipped with either intermittent or continuous-duty solenoids. The electrical pulse to operate low resistance, intermittent-duty solenoid operators for momentary electric contact service can be provided by capacitor discharge supplied from 24-V batteries.

References

1. Humpherys, A. S. and R. L. Stacey. 1975. Automatic valves for surface irrigation pipelines. Proc. Am. Soc. Civil Engrs., J. of the Irrig. and Drain. Div. 101(IR2):95-109.

‡The Patentrol Co., Cleveland, OH.