

SPRINKLER IRRIGATION EFFECTS ON INFILTRATION AND NEAR-SURFACE UNSATURATED HYDRAULIC CONDUCTIVITY

G. A. Lehrs, D. C. Kincaid

ABSTRACT. *Sprinkler irrigation alters soil hydraulic properties both at and below the soil surface, yet its effects are not well characterized. We evaluated the effects of sprinkler irrigation on infiltration and near-surface hydraulic conductivity (K) measured under tension in a poorly structured, recently roller-harrowed Portneuf silt loam (Durinodic Xeric Haplocalcid). The experimental design was a randomized complete block with two treatments (pre- and post-irrigation) and four replications. We used two half-circle spray heads to apply 127 mm of water at 70 mm h⁻¹ in one irrigation to duplicate 1 × 2 m plots. Unconfined (three-dimensional) infiltration rates at steady-state were measured at potentials of -55, -35, and -15 mm of water before and about 10 days after irrigation. Irrigation increased surface bulk density (0 to 34 mm) by 18% and increased the saturation ratio by 35%. At -15 mm, the unconfined infiltration rate was 53 mm h⁻¹ before, but 16 mm h⁻¹ after irrigation. At -35 and -55 mm, irrigation decreased infiltration by 68%. Irrigation also decreased infiltration nearly 5-fold through pores with diameters ranging from 0.55 to 0.86 mm. At each measured potential, irrigation tended to decrease hydraulic conductivity by 48%, on average. Sprinkler droplet impact consolidated unprotected soil and greatly reduced tension infiltration. Our findings provide useful input data regarding this and similar soils for models requiring hydraulic properties. In addition, our results provide valuable insight for managing infiltration and avoiding runoff during a growing season when surface properties change as recently tilled soils are sprinkler irrigated.*

Keywords. *Droplet energy, Hydraulic conductivity, Infiltration, Infiltrimeters, Intake, Sprinkler irrigation, Surface sealing.*

Infiltration determines a soil's runoff response to irrigation and rainfall. Excessive runoff that occurs when irrigation or rainfall rates exceed the soil's infiltration rate has eroded many soils in the Pacific Northwest and worldwide, impairing their hydraulic properties and decreasing their productivity (Arriaga and Lowery, 2003; Robbins et al., 1997). Erosion also commonly exposes subsurface horizons with poorer structure, lower infiltration rates, and reduced hydraulic conductivities (Rasmussen and Cary, 1979). Soil hydraulic property inputs are urgently needed to model, for example, irrigation-induced erosion (Sojka et al., 2007).

In addition to runoff, raindrop or sprinkler droplet impact also alters soil physical properties. Water droplet kinetic energy fractures surface aggregates, particularly early in an irrigation or rainstorm, and forms a surface seal that impedes infiltration (Römken et al., 1990; Santos et al., 2003; Thompson and James, 1985). Messing and Jarvis (1993) found that near-surface unsaturated hydraulic conductivity decreased with time during the growing season, likely as a consequence of aggregate breakdown from raindrop impact

over the long-term. Water droplet kinetic energy is thought to alter the hydraulic properties of tilled soils (Somaratne and Smettem, 1993) by collapsing macropores, blocking them with detached soil, or both (Messing and Jarvis, 1993; Murphy et al., 1993). Raindrop or sprinkler droplet impact also consolidates soil, increasing its bulk density and altering its pore size distribution (Baver et al., 1972; Yonts and Palm, 2001). In an interesting analogy, surge flow surface irrigation also consolidates tilled soil, reducing its intake and thereby minimizing intake opportunity time differences from furrow head to tail (Trout and Kincaid, 1987).

Maintaining adequate infiltration is critical, particularly into sites where manure, compost, or other organic materials have been applied, to minimize off-site transport of both nutrients and sediment in runoff, be it from either rainfall or irrigation (Gilley et al., 2002; Trout and Kincaid, 1987; Wuest et al., 2005). Water quality can be degraded not only by nutrients and agricultural chemicals transported via overland flow but also via subsurface flow. Characterization of both saturated and unsaturated hydraulic properties is needed to properly design and operate irrigation systems and to better understand and model both transient water movement and solute transport in the vadose zone (Angulo-Jaramillo et al., 2000; Trout and Kincaid, 1987). Since most solute transport occurs in soils that are saturated or nearly so, it is particularly important to know soil hydraulic properties at soil water potentials on the order of -150 mm H₂O and above, where preferential flow may occur (Reynolds et al., 1995; Sojka et al., 2009).

Angulo-Jaramillo et al. (2000) noted the need for better characterization of unsaturated flow both into and through soils affected by both crop and soil management practices. Soil hydraulic properties, along with temporal changes in

Submitted for review in November 2008 as manuscript number SW 7825; approved for publication by the Soil & Water Division of ASABE in February 2010.

Manufacturer or trade names are included for the reader's benefit. The USDA-ARS neither endorses nor recommends such products.

The authors are **Gary A. Lehrs**, Soil Scientist, and **Dennis C. Kincaid**, **ASABE Member Engineer**, Agricultural Engineer (retired), USDA-ARS Northwest Irrigation and Soils Research Laboratory, Kimberly, Idaho. **Corresponding author:** Gary A. Lehrs, USDA-ARS Northwest Irrigation and Soils Research Laboratory, 3793 N. 3600 E., Kimberly, ID 83341-5076; phone: 208-423-6508; fax: 208-423-6555; e-mail: Gary.Lehrs@ars.usda.gov.

those properties, can be effectively studied using tension infiltrometers (Everts and Kanwar, 1993; Hussen and Warrick, 1995; Somaratne and Smettem, 1993; White et al., 1992). The infiltrometer's pre-set water supply potential determines the upper limit of pore diameters through which flow occurs (Baver et al., 1972; Reynolds et al., 1995). Their use in characterizing soil hydraulic properties has been reviewed (Angulo-Jaramillo et al., 2000; White et al., 1992).

Using tension infiltrometers, changes in hydraulic properties caused by topography, time, tillage, and other soil and crop management practices have been studied by many researchers (e.g., Chan and Heenan, 1993; Heddadj and Gascuel-Oudou, 1999; Logsdon et al., 1993; Messing and Jarvis, 1993; Schwartz et al., 2003). Hydraulic property responses to a single irrigation or a lone rainfall, in contrast, have been studied by few (Murphy et al., 1993; Somaratne and Smettem, 1993). Moreover, Logsdon et al. (1993) and Strudley et al. (2008) stressed the need for studies of irrigation or rainfall effects on recently tilled soil hydraulic properties. Our objective was to determine the effects of one sprinkler irrigation on both unconfined infiltration and near-surface unsaturated hydraulic conductivity on a recently tilled, highly productive soil from the Pacific Northwest.

MATERIALS AND METHODS

EXPERIMENTAL SITE, TREATMENTS, AND PLOT PREPARATION

The experiment was conducted on a structurally unstable Portneuf silt loam (coarse-silty, mixed, superactive, mesic Durinodic Xeric Haplocalcid) at 42° 31.12' N, 114° 22.44' W, about 1.7 km southwest of Kimberly, Idaho. To determine soil texture, in the fall of 1998 disturbed samples were collected from the Ap horizon, 0 to 0.3 m. The samples were mixed, subsampled, sieved through a 2 mm screen, and air-dried. Particle size distributions were then determined in duplicate using the hydrometer method (Gee and Or, 2002). To determine soil chemical properties, five samples were collected with a 75 mm diameter bucket auger, also to a depth of 0.3 m, from each plot in the spring of 1998. The samples were sieved through a 2 mm screen, mixed, and then air-dried prior to analysis (Robbins et al., 2000). For each sample, soil organic carbon (SOC) was measured using the Walkley-Black procedure (Nelson and Sommers, 1996). We analyzed the samples for saturation paste pH and, in the saturated paste extract, we measured electrical conductivity (EC) and soluble K, Na, Ca, and Mg (Robbins and Wiegand, 1990). Using the measured cation concentrations in each extract, we calculated the sodium adsorption ratio, SAR (Robbins and Wiegand, 1990). Results are shown in table 1. Also shown are cation exchange capacity (CEC) values reported by McDole and Maxwell (1987) and CaCO₃ equivalents reported by Robbins et al. (2000). The Portneuf soil exhibited little shrinking or swelling since its predominant coarse clay was illite (Lentz et al., 1996). Portneuf aggregates on the soil surface are known to fracture readily with only moderate energy input (Lehrsch and Kincaid, 2001). Additional soil characteristics were given by McDole and Maxwell (1987).

We studied the effects of irrigation on surface soil hydraulic properties in October 1998 near Kimberly, Idaho, in selected 9 m wide × 21 m long plots of an experiment described by Robbins et al. (1997, 2000). Our field experiment was

Table 1. Properties of the Ap horizon (0 to 0.3 m depth) of Portneuf silt loam.

Property	Value
Physical	
Particle size distribution (g kg ⁻¹)	
Sand (0.05 to 2 mm)	190
Silt (0.002 to 0.05 mm)	580
Clay (<0.002 mm)	230
Chemical	
Soil organic C (g kg ⁻¹)	8.8
pH (sat. paste)	7.8
Electrical cond. (sat. paste ext.) (dS m ⁻¹)	0.54
Soluble K (mg kg ⁻¹)	8.2
Soluble Na (mg kg ⁻¹)	8.5
Sodium adsorption ratio (SAR)	0.47
Cation exchange capacity (cmol _c kg ⁻¹)	21
CaCO ₃ equivalent (g kg ⁻¹)	80

conducted in a narrow window in time to minimize the effects of soil C loss due to high rates of biological oxidation in many soils, including those in the Pacific Northwest (Rasmussen et al., 1998), and short-term changes in hydraulic properties (Fuentes et al., 2004) and surface soil structure due to changing climatic conditions (Angers, 1998).

Dry bean (*Phaseolus vulgaris* L. 'Viva Pink') was harvested from our plots on 17-18 September 1998. Three days before each plot was irrigated, it was tilled with an offset disk to a depth of 0.14 m and then immediately roller-harrowed twice to a depth of 70 mm. All plots were tilled identically since infiltration generally varies from one tillage practice to another (DeBoer and Chu, 2001; Pikul and Zuzel, 1994; Schwartz et al., 2003). After tillage, plot surfaces were gently raked smooth without removing the minimal dry bean residue from the soil surface.

Within two days after tillage, duplicate runoff plots (each 1.0 × 2.0 m with the long axis parallel to the uniform, 1.1% slope) were established within a 3 × 4 m area near the center of each of our four study plots (fig. 1). The runoff plots were 0.75 m from one another across the slope. Metal borders

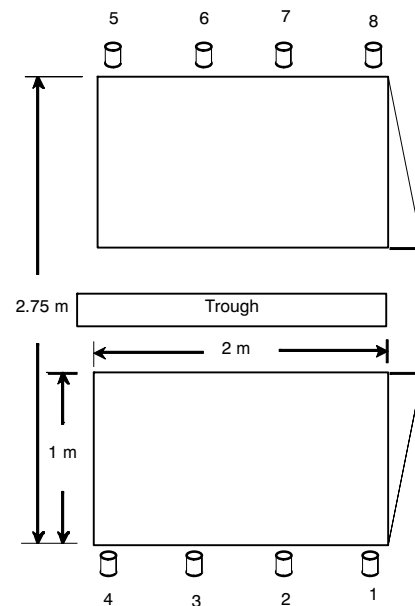

Figure 1. Positioning of the runoff plots, catch cans, and trough within each plot of the study.

(about 0.05 m above and 0.1 m below ground) established runoff boundaries. An 18-gauge, metal collector was installed flush with the soil surface at the lower edge of each plot to funnel runoff into a container. The collector and container were covered to exclude water that fell outside the plot boundary.

TENSION INFILTRATION MEASUREMENTS AND SOIL SAMPLING

Tension infiltrometers (Ankeny, 1992; Hussen and Warwick, 1995) with 0.11 m diameter bases were used to measure *in situ* unconfined (three-dimensional) infiltration rates at steady-state 1 or 2 days before the irrigation (“pre-irrigation” measurement) and again about 10 days after irrigation (“post-irrigation” measurement). Before each large plot was irrigated, we measured tension infiltration at one site between two runoff plots (described below). After each large plot was irrigated, we again measured tension infiltration at one site, although this time within the borders of a randomly selected runoff plot. At a representative location, tension infiltration was measured through a 115 mm diameter, sand-filled ring using a procedure similar to that of Ankeny (1992). We measured infiltration into an undisturbed surface and from pre-calibrated, small to large water supply potentials (–60, –40, and –20 mm, or –0.6, –0.4, and –0.2 kPa). After accounting for the contact sand’s thickness (about 6 mm) and saturated hydraulic conductivity ($1.09 \times 10^{-1} \text{ mm s}^{-1}$), we found that the potentials imposed at the soil surface on average were –55, –35, and –15 mm H₂O (Reynolds, 2008). We chose a water supply potential of –35 mm to give us a baseline measure of hydraulic properties of the soil matrix little affected by management and biological activity (Angulo-Jaramillo et al., 2000; Murphy et al., 1993; Somaratne and Smettem, 1993; White et al., 1992). Potentials above and below –35 mm were selected to bracket this breakpoint, in part because Murphy et al. (1993) reported that hydraulic conductivity calculated using unconfined infiltration measured at a greater potential, –10 mm in their case, best detected soil structural change.

At a water supply potential of –55 mm, flow occurred through pores with diameters ≤ 0.55 mm, at –35 mm through pores ≤ 0.86 mm, and at –15 mm through pores ≤ 2.0 mm, with pore diameters based upon capillary rise theory (Baver et al., 1972; Somaratne and Smettem, 1993). The diameters of flow-conducting pores at each potential can also be estimated using other techniques (Angulo-Jaramillo et al., 2000; Reynolds, 2008; Reynolds et al., 1995). We manually recorded elapsed time at every 10 or 20 mm drop in the elevation of the water surface in the infiltrometer’s supply reservoir until the infiltration rate stabilized at each potential. On average, infiltration was measured for 0.49 (± 0.23) h \pm standard deviation, SD), sufficient for 149 (± 41) mL of water to infiltrate at each potential. Without moving the infiltrometer, we measured infiltration sequentially, from one potential to the next, into the same 115 mm diameter area. We used software (Ankeny et al., 1993) to determine unconfined infiltration rates at steady-state at each of the three potentials and to calculate unsaturated hydraulic conductivities by taking infiltration rates at two adjacent potentials as data to simultaneously solve three equations with three unknowns. The solution yielded the hydraulic conductivity at each potential (Ankeny et al., 1993).

When tension infiltration was measured before irrigation, we collected three 51 mm diameter, volumetric soil samples from the 0 to 34 mm depth at undisturbed locations within 0.3 m of the infiltration measurement site. Soil bulk density was measured on each of these samples (Grossman and Reinsch, 2002). After measuring infiltration at –15 mm potential at each site, we quickly removed the infiltrometer and contact sand, with removal of the latter facilitated by a double layer of cheesecloth between the sand and soil. A gravimetric soil sample was immediately collected from the uppermost 30 to 40 mm of wetted soil beneath the containment ring. The wetted zone beneath the infiltrometer was about 0.1 m deep, similar to that found by others for medium-textured soils (Thony et al., 1991). The gravimetric sample was sealed in a sample can and transported to the laboratory. The wetted zone sample’s gravimetric water content was converted to volumetric water content using the mean surface bulk density measured on the three volumetric samples taken before tension infiltration was measured (Thony et al., 1991). This volumetric water content was expressed as a saturation ratio, the water-filled fraction of the soil’s pore space. These tension infiltration, bulk density, and water content measurements were repeated after irrigation.

IRRIGATION AND RUNOFF COLLECTION

After measuring tension infiltration, we sprinkler irrigated each pair of runoff plots, on average one pair every three days from 6 to 20 October 1998. Water was applied with a locally designed sprinkler simulator, consisting of two metal stands, each with a tripod base, positioned 6.0 m apart perpendicular to the slope. On each stand, a Nelson 2000 half-circle irrigation spray head was operated at 140 kPa nozzle pressure and equipped with a 7.9 mm nozzle and a spinning, six-groove deflector plate 3.0 m above the soil surface. This sprinkler apparatus produced droplet characteristics similar to those at the outer spans of the region’s center pivots. In particular, this spray head and deflector plate combination operated as described produced droplets with kinetic energy of about 14 J kg⁻¹ (Kincaid, 1996). Droplet energies of 10 J kg⁻¹ or more are typical for center pivots with single-nozzle, impact-type sprinklers in southern Idaho when no wind is present (Kincaid, 1996). The irrigation water we used, from the Snake River, had a pH of 8.2, electrical conductivity of 0.5 dS m⁻¹, and SAR of 0.7 (Westermann et al., 2001).

Sprinkler irrigation was simulated using an intensity of 70 mm h⁻¹, typical of the region’s pivot outer spans. Water was applied in the field at a relatively constant intensity by monitoring and adjusting nozzle pressures at the spray heads. Wind, however, caused the intensity to vary somewhat. Gross water application was measured using a trough positioned between the runoff plots and four catch cans along the outside edge of each plot (fig. 1). Runoff rate was measured by timing the manual collection of all runoff as discrete samples from each plot. Once continuous runoff began from each plot, we collected 1.0 L runoff samples and then 2.5 L samples until we determined in the field that the runoff rate had stabilized at its maximum, i.e., until steady-state infiltration was reached. In our single irrigation on average, we applied 127 (± 28) mm of water at 70 (± 2) mm h⁻¹ intensity with 51% ($\pm 5\%$) running off. Steady-state one-dimensional infiltration rates for each runoff plot were calculated using the slope of a line fitted, in general, to the last 8 to 12 points of cumulative net infiltration as a function of time from the irrigation tests.

EXPERIMENTAL DESIGN, DATA HANDLING, AND STATISTICAL ANALYSES

The experimental design was a randomized complete block with two treatments (pre- and post-irrigation) and four replications. The steady-state infiltration rates (measured by irrigation) from each pair of runoff plots within each study plot were arithmetically averaged prior to statistical analyses. After employing a common log transformation to stabilize the error variances of both unconfined infiltration and hydraulic conductivity at each potential, we performed a likelihood ratio test (SAS, 2009) to ensure that each response variable's irrigation treatment variances were homogeneous. We then performed an analysis of variance at each potential using mixed-model techniques (SAS, 2009) and a significance probability (*p*) of 0.05. Least-squares means were separated using *t*-tests of pairwise differences. Where needed, means were back-transformed into original units for presentation.

RESULTS AND DISCUSSION

SOIL PROPERTIES: STATISTICAL SUMMARY

Soil property minimum, maximum, mean, and standard deviation values are shown in table 2. The measured values of bulk density and saturation ratio were clustered in a relatively narrow range about their respective means with no overlap between the pre- and post-irrigation ranges. On the other hand, the unconfined infiltration rates at each potential exhibited much wider ranges. In addition, the pre- and post-irrigation ranges overlapped at -15 mm and nearly overlapped at -35 mm. The ranges for the hydraulic conductivities at potentials of -15 mm and -35 mm were also wide. On average, maximum values were about 9-fold greater than the minimum for the pre-irrigation measurements and 4-fold greater for the post-irrigation measurements (table 2). The standard deviations reflected the ranges of the values of the individual measurements of each parameter. While not reported in table 2, the standard errors of both infiltration and hydraulic conductivity, when measured pre-irrigation and when measured post-irrigation, increased as supply potentials approached 0 mm (i.e., saturation). This response, often observed at similar potentials by others (Clothier and Smettem, 1990; Somaratne and Smettem, 1993), likely reflects the increasing contribution of macropores to the flow process (Smettem, 1987) and is important when modeling water flow and solute transport through dual-pore (matrix-macropore) soil profiles with some regions containing mobile water and others immobile water (Angulo-Jaramillo et al., 2000). While not shown in table 2, the coefficients of variation (CVs) for bulk density and saturation ratio were 8% or less while the CVs for infiltration rate and hydraulic conductivity varied from 19% to 73%, with most exceeding 40%. These large CVs reflect the fact that these water flow parameters are commonly log-normally distributed (Everts and Kanwar, 1993; Reynolds et al., 1995). Thus, all subsequent analyses of infiltration rate and hydraulic conductivity were performed using common log-transformed values.

While hydraulic properties at each of three supply potentials were measured in all plots of our study, not all measurements could be used. In particular, we had few valid measures of either pre- or post-irrigation unconfined

Table 2. Irrigation effects on physical properties, infiltration rates, and hydraulic conductivities.

Property	<i>n</i>	Min.	Max.	Arith. Mean	SD
Bulk density (Mg m⁻³)					
Pre-irrigation	4	0.99	1.04	1.02	0.02
Post-irrigation	4	1.17	1.22	1.20	0.02
Saturation ratio (m³ m⁻³)					
Pre-irrigation	4	0.49	0.58	0.53	0.04
Post-irrigation	4	0.65	0.78	0.71	0.06
Unconfined infiltration rate (mm h⁻¹)					
At -15 mm, pre-irrig.	4	32.39	89.32	57.05	24.1
At -15 mm, post-irrig.	3	8.23	35.68	19.59	14.3
At -35 mm, pre-irrig.	4	31.24	75.94	48.57	19.6
At -35 mm, post-irrig.	4	6.00	28.29	16.17	10.2
At -55 mm, pre-irrig.	1	29.49	29.49	29.49	NA ^[a]
At -55 mm, post-irrig.	2	8.15	12.37	10.26	3.0
Steady-state infiltration rate from sprinkler irrig. (mm h⁻¹)					
	4	15.27	23.27	18.44	3.5
Unsaturated hydraulic cond. (mm h⁻¹)					
At -15 mm, pre-irrig.	4	2.42	24.02	14.91	9.0
At -15 mm, post-irrig.	3	3.41	12.25	7.61	4.4
At -35 mm, pre-irrig.	4	2.34	20.42	12.62	7.5
At -35 mm, post-irrig.	4	2.48	10.96	6.73	4.2
At -55 mm, pre-irrig.	1	10.83	10.83	10.83	NA
At -55 mm, post-irrig.	2	2.36	6.57	4.47	3.0

[a] NA = not applicable.

infiltration rates at -55 mm potential. When infiltration rates were measured in the field, those rates often decreased slightly, rather than increased, from -55 to -35 mm H₂O potential. We believe that these unexpected decreases in infiltration rates were due to settling of soil under the tension infiltrometers as the soil's bearing capacity decreased due to wetting. The soil settling increased soil bulk density and produced changes in pore size distributions at the surface, as well as below it. Indeed, where infiltration rates decreased from -55 mm to -35 mm, the decreases were 10 times greater when measured pre-irrigation versus post-irrigation. Compared to soil consolidated by sprinkler droplet kinetic energy, our recently tilled soil had a far lower bearing capacity and bulk density (discussed below), reflected in the much greater change in infiltration rates from -55 to -35 mm when measured pre-irrigation versus post-irrigation. In the post-irrigation measurement of one other plot, the infiltration rate decreased by nearly half, from -35 to -15 mm. These infiltration rate decreases with increasing potential violated theory (Ankeny, 1992; White et al., 1992), led to unrealistic measures of hydraulic conductivity (Hussen and Warrick, 1995), and were obviously aberrant measurements or artifacts of the infiltrometer's load pressure. Hence, per the recommendation of Reynolds (2008), we coded these values as missing, thus eliminating them from subsequent calculations.

BULK DENSITY AND SATURATION RATIO

Irrigation affected both bulk density and saturation ratio (table 3). One irrigation increased bulk density at the 0 to 34 mm depth by 18%, significant at *p* < 0.001. Bulk density increased due to (1) consolidation of the freshly tilled soil and (2) compaction caused by 14 J kg⁻¹ of droplet kinetic energy (Somaratne and Smettem, 1993; Trout and Kincaid, 1987; Yonts and Palm, 2001). Just as bulk density increased in our

Table 3. Irrigation effects on bulk density and saturation ratio after measuring tension infiltration. Both properties were measured at the 0 to 34 mm depth.^[a]

Irrigation	Bulk Density (Mg m ⁻³)	Saturation Ratio (m ³ m ⁻³)
Pre-irrigation	1.02 b	0.526 b
Post-irrigation	1.20 a	0.709 a

^[a] Within a column, means ($n = 4$) followed by different letters are significantly different (t -test of pairwise differences at $p = 0.05$).

study, the saturation ratio of the wetted soil beneath our tension infiltrometers also increased ($p < 0.010$) by 35% as a consequence of the irrigation (table 3). This saturation ratio increase was likely due to two factors. First, total porosity (not reported) decreased as a consequence of the bulk density increase caused by sprinkler droplet kinetic energy. Second, the soil's pore size distribution changed because irrigation increased bulk density. As density increased, the proportion of small pores increased while the proportion of large pores decreased, since the larger pores collapsed (Baver et al., 1972). One might assume, then, that the proportion of pores with diameters ≤ 2.0 mm increased at the expense of pores > 2.0 mm. Recall that, at a potential of -15 mm, pores ≤ 2.0 mm were conducting flow and, thus, were water-filled when soil was sampled immediately after tension infiltration was measured. Since there were likely more of these ≤ 2.0 mm, water-filled pores after the irrigation, the soil's saturation ratio increased following irrigation.

TENSION INFILTRATION

One prolonged, intense irrigation decreased unconfined infiltration at each potential, significantly so at -15 and -35 mm (fig. 2). On a relative basis, irrigation effects at each potential were remarkably similar. A single irrigation decreased infiltration by 69% at -15 mm, by 70% at -35 mm, and by 66% at -55 mm. On average then, tension infiltration from -15 to -55 mm decreased by 68% as a consequence of irrigation. Sprinkler droplet impact energy caused structural breakdown (Lehrsch and Kincaid, 2006; Santos et al., 2003), forming a seal that reduced infiltration (Römken et al., 1990; Thompson and James, 1985). Moreover, droplet impact and subsequent drying consolidated the recently tilled soil at the plot surfaces (Logsdon et al., 1993; Yonts and Palm, 2001). The post-irrigation unconfined infiltration rates at -15 and -35 mm (fig. 2) are comparable to infiltration rates at similar potentials measured on the same soil but at a different site after being repeatedly irrigated at a much lower intensity, 6.4 mm h^{-1} , with a solid-set sprinkler system (Lehrsch and Gallian, 2010).

Irrigation decreased flow nearly twice as much through small pores (from 0.55 to 0.86 mm) relative to large pores (from 0.86 to 2.0 mm). Data shown in figure 2 reveal that the infiltration rate decrease from -35 to -55 mm was more than 4.6-fold greater when measured pre- versus post-irrigation, but only 2.7-fold greater from -15 to -35 mm when measured pre- versus post-irrigation. Stated differently, flow through pores with diameters from 0.55 to 0.86 mm was nearly 5 times greater before than after the irrigation. Similarly, flow through pores from 0.86 to 2.0 mm was only 2.7 times greater before than after the irrigation. In other words, one simulated center-pivot irrigation decreased infiltration by a factor of almost 5 through pores from 0.55 to 0.86 mm but only by a factor of 2.7 through pores from 0.86 to 2.0 mm.

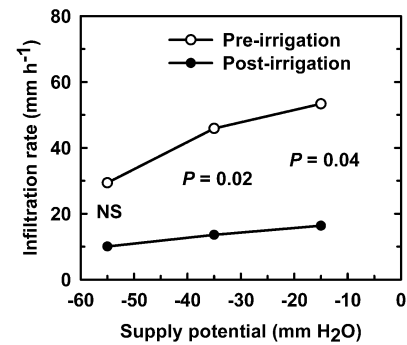

Figure 2. Irrigation effects on unconfined infiltration rates measured at supply potentials from -55 to -15 mm H₂O. Pre- and post-irrigation means at each potential are significantly different at the p -values shown or are not significantly different (at $p = 0.05$) where NS is shown.

Messing and Jarvis (1993) also found raindrop impact to affect flow more through smaller than larger pores. In contrast, Lehrsch and Kincaid (2001) and Somaratne and Smettem (1993) found droplet kinetic energy to affect flow more through larger than smaller pores. Compared to smaller aggregates, larger aggregates are generally less stable (Six et al., 2004). Droplet energy, known to fracture Portneuf aggregates (Lehrsch and Kincaid, 2006), may preferentially disintegrate larger surface aggregates, with their fragments obstructing pores of all sizes, depending on the soil's structure and pore size distribution. Management practices that stabilize surface aggregates will help to reduce surface sealing, sustain infiltration rates, and minimize runoff. Such soil and crop management practices may include using minimum tillage or no-tillage, maintaining residues as a mulch on the soil surface, applying whey or polyacrylamide (PAM), or choosing crop rotations that include a grass or forage species (Bjorneberg et al., 2003; Lehrsch et al., 2005; Lehrsch et al., 2008; Pikul and Zuzel, 1994; Wuest et al., 2005).

HYDRAULIC CONDUCTIVITY

Irrigation always reduced near-surface unsaturated hydraulic conductivity at potentials ≥ -55 mm (fig. 3). We attribute these decreases in hydraulic conductivity caused by irrigation to (1) soil consolidation from droplet kinetic energy and (2) aggregate breakdown and pore occlusion in the near-surface environment (Somaratne and Smettem,

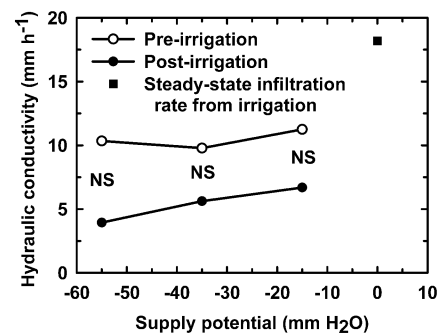

Figure 3. Irrigation effects on hydraulic conductivity at supply potentials from -55 to -15 mm H₂O. Also shown is the steady-state infiltration rate measured from runoff plots irrigated at an intensity of 70 mm h^{-1} . Pre- and post-irrigation means at each potential are not significantly different (at $p = 0.05$) where NS is shown.

1993). Aggregate fragments and soil in suspension were apparently transported by infiltrating water into the subsurface, there to be deposited in smaller pores, initiating the formation of an illuvial layer with greater bulk density (table 3) and reduced hydraulic conductivity (fig. 3). Messing and Jarvis (1993), who also detected decreases in conductivity during one growing season, cited possible causes as raindrop impact, structural deterioration, and blockage of conducting pores.

While irrigation consistently decreased conductivity at each supply potential (fig. 3), irrigation effects were not significant at $p = 0.05$. Somaratne and Smettem (1993), who studied simulated rainfall effects, and Messing and Jarvis (1993), who studied temporal effects, also experienced difficulty in statistically separating some hydraulic conductivities calculated using tension infiltration data. In our study of a Portneuf silt loam, irrigation effects were significant upon tension infiltration (fig. 2) but not upon hydraulic conductivity. The fact that irrigation effects were greater, indeed significantly so, upon infiltration than conductivity is logical. Kinetic energy from sprinkler droplets or raindrops primarily affects soil at the surface, exerting in the short term only secondary effects on soil structure and pore size distributions deeper than a few millimeters (McIntyre, 1958). In contrast, hydraulic conductivities calculated using tension infiltration data characterize flow through a deeper portion of the profile, the upper 30 to 50 mm or so (Sauer and Logsdon, 2002; Thony et al., 1991), depending upon the volume of water infiltrated. Soil below the surface, after being disrupted by tillage or subsoiling, will nonetheless reconsolidate upon wetting as time passes (Cassel and Nelson, 1985). Perhaps the decreases in hydraulic conductivity caused by irrigation that we measured (fig. 3) reflect the beginning of this reconsolidation process. The differences that we measured in hydraulic conductivity at each potential could not be declared significant because the absolute magnitude of the decreases in conductivity caused by irrigation were slight when compared to the decreases measured in unconfined infiltration. To illustrate, irrigation caused decreases from 19 to 37 mm h⁻¹ in infiltration but only from 4 to 7 mm h⁻¹ in hydraulic conductivity. Such slight differences in conductivity are difficult to declare statistically significant in field studies where both material and personnel resources are frequently limiting.

While not significant at $p = 0.05$, decreases in conductivity caused by irrigation were consistent from potentials ranging from -55 to -15 mm (fig. 3). Indeed, when we considered the three potentials as a group, we found that irrigation decreased hydraulic conductivity at $p < 0.160$. On average, hydraulic conductivity values at each potential tended to be 48% lower after than before irrigation. Somaratne and Smettem (1993) reported that hydraulic conductivity at -20 mm in a recently tilled sandy loam decreased by 3.4-fold, to 4.5 mm h⁻¹, due to simulated rainfall. In our study of a silt loam, hydraulic conductivity at -15 mm also tended to be lower due to irrigation but to a far lesser degree. Their post-rainfall value of 4.5 mm h⁻¹ was similar to our post-irrigation value of 6.7 mm h⁻¹ but a bit less, likely due to (1) fewer water-conducting pores <0.55 mm in their coarser-textured soil and (2) a slightly lower supply potential at which conductivity was reported.

Since irrigation caused hydraulic conductivity from -55 to -15 mm to decrease by a relatively similar proportion (fig. 3), irrigation thus tended to decrease hydraulic conductivity equally through pores from 0.55 to 2.0 mm in diameter. At the surface, droplet kinetic energy decreased infiltration more through pores from 0.55 to 0.86 mm than from 0.86 to 2.0 mm (fig. 2), likely due to surface aggregate breakdown and pore occlusion. Below the surface, in contrast, flow through small pores was affected as much as flow through larger pores. Below the soil surface, aggregates were not affected by kinetic energy and were far less affected by slaking, due to slower rates of wetting. Thus, because aggregates along pore sidewalls likely experienced less breakdown, flow through both large and small pores was less hindered by fragments of unstable aggregates (Lehrsch and Kincaid, 2001; Murphy et al., 1993).

Sprinkler droplet kinetic energy, while decreasing tension infiltration (fig. 2), tends to reduce near-surface unsaturated hydraulic conductivity as well (fig. 3). Moret and Arrué (2007) also reported that, compared to freshly tilled soil, rainfall decreased near-surface hydraulic conductivity because bulk density increased. We, too, found bulk density to increase after irrigation (table 3).

STEADY-STATE INFILTRATION FROM SPRINKLER IRRIGATION

The steady-state, or final, one-dimensional infiltration rate from simulated center-pivot irrigations, having a geometric mean of 18.2 mm h⁻¹, was of the same order of magnitude as the post-irrigation, hydraulic conductivities measured at three water potentials (fig. 3). Steady-state infiltration is an approximate measure of a homogeneous soil's saturated hydraulic conductivity, though often a bit less due to air entrapment and incomplete saturation of soil wetted by rainfall or irrigation (Baver et al., 1972). If one assumes that 18.2 mm h⁻¹ approximated our recently tilled Portneuf soil's saturated hydraulic conductivity, then the soil's hydraulic conductivity at saturation exceeded that measured at -15 mm by about 2.7-fold, revealing significant flow through subsurface pores with diameters >2.0 mm.

SUMMARY AND CONCLUSIONS

One simulated center-pivot irrigation of recently roller-harrowed Portneuf silt loam increased surface bulk density by 18% and saturation ratio by 35%. That same irrigation decreased steady-state infiltration by 68% at water potentials ranging from -55 to -15 mm. Stated differently, the irrigation decreased infiltration by 68% through pores with diameters ≤ 2.0 mm. Irrigation reduced infiltration nearly 5-fold through surface pores with diameters from 0.55 to 0.86 mm. Irrigation tended to decrease hydraulic conductivity by an average of 48% at each of three measured potentials. Steady-state infiltration rates calculated using runoff data from a simulated irrigation were of the same order of magnitude as hydraulic conductivities.

ACKNOWLEDGEMENTS

The authors thank J. A. Foerster, L. L. Freeborn, S. B. Hansen, P. M. Jolley, M. A. Kay, and A. Mutziger for field operations, data collection, laboratory analyses, preliminary data handling, and figure preparation.

REFERENCES

- Angers, D. A. 1998. Water-stable aggregation of Quebec silty clay soils: Some factors controlling its dynamics. *Soil Tillage Res.* 47(1-2): 91-96.
- Angulo-Jaramillo, R., J.-P. Vandervaere, S. Roulier, J.-L. Thony, J.-P. Gaudet, and M. Vauclin. 2000. Field measurement of soil surface hydraulic properties by disc and ring infiltrometers: A review and recent developments. *Soil Tillage Res.* 55(1-2): 1-29.
- Ankeny, M. D. 1992. Methods and theory for unconfined infiltration measurements. In *Advances in Measurement of Soil Physical Properties: Bringing Theory into Practice*, 123-141. G. C. Topp, W. D. Reynolds, and R. E. Green, eds. Spec. Publ. 30. Madison, Wisc.: SSSA.
- Ankeny, M. D., M. A. Prieksat, T. C. Kaspar, and K. M. Noh. 1993. FLOWDATA: Software for analysis of infiltration data from automated infiltrometers. *Agron. J.* 85(4): 955-959.
- Arriaga, F. J., and B. Lowery. 2003. Soil physical properties and crop productivity of an eroded soil amended with cattle manure. *Soil Sci.* 168(12): 888-899.
- Baver, L. D., W. H. Gardner, and W. R. Gardner. 1972. *Soil Physics*. 4th ed. New York, N.Y.: John Wiley and Sons.
- Bjorneberg, D. L., F. L. Santos, N. S. Castanheira, O. C. Martins, J. L. Reis, J. K. Aase, and R. E. Sojka. 2003. Using polyacrylamide with sprinkler irrigation to improve infiltration. *J. Soil Water Cons.* 58(2): 283-289.
- Cassel, D. K., and L. A. Nelson. 1985. Spatial and temporal variability of soil physical properties of Norfolk loamy sand as affected by tillage. *Soil Tillage Res.* 5(1): 5-17.
- Chan, K. Y., and D. P. Heenan. 1993. Surface hydraulic properties of a red earth under continuous cropping with different management practices. *Australian J. Soil Res.* 31(1): 13-24.
- Clothier, B. E., and K. R. J. Smettem. 1990. Combining laboratory and field measurements to define the hydraulic properties of soil. *SSSA J.* 54(2): 299-304.
- DeBoer, D. W., and S. T. Chu. 2001. Sprinkler technologies, soil infiltration, and runoff. *J. Irrig. Drainage Eng. ASCE* 127(4): 234-239.
- Everts, C. J., and R. S. Kanwar. 1993. Interpreting tension-infiltrometer data for quantifying soil macropores: Some practical considerations. *Trans. ASAE* 36(2): 423-428.
- Fuentes, J. P., M. Flury, and D. F. Bezdicek. 2004. Hydraulic properties in a silt loam soil under natural prairie, conventional till, and no-till. *SSSA J.* 68(5): 1679-1688.
- Gee, G. W., and D. Or. 2002. Particle-size analysis. In *Methods of Soil Analysis: Part 4. Physical Methods*, 255-293. J. H. Dane and G. C. Topp, eds. SSSA Book Ser. 5. Madison, Wisc.: SSSA.
- Gilley, J. E., L. M. Risse, and B. Eghball. 2002. Managing runoff following manure application. *J. Soil Water Cons.* 57(6): 530-533.
- Grossman, R. B., and T. G. Reinsch. 2002. Bulk density and linear extensibility. In *Methods of Soil Analysis: Part 4. Physical Methods*, 201-228. J. H. Dane and G. C. Topp, eds. SSSA Book Ser. 5. Madison, Wisc.: SSSA.
- Heddadj, D., and C. Gascuel-Oudou. 1999. Topographic and seasonal variations of unsaturated hydraulic conductivity as measured by tension disc infiltrometers at the field scale. *European J. Soil Sci.* 50(2): 275-283.
- Hussen, A. A., and A. W. Warrick. 1995. Tension infiltrometers for the measurement of vadose zone hydraulic properties. In *Handbook of Vadose Zone Characterization and Monitoring*, 189-201. L. G. Wilson, L. G. Everett, and S. J. Cullen, eds. Boca Raton, Fla.: Lewis Publishers.
- Kincaid, D. C. 1996. Spraydrop kinetic energy from irrigation sprinklers. *Trans. ASAE* 39(3): 847-853.
- Lehrsch, G. A., and J. J. Gallian. 2010. Oilseed radish effects on soil structure and soil water relations. *J. Sugar Beet Res.* 47(1-2): 1-21.
- Lehrsch, G. A., and D. C. Kincaid. 2001. Sprinkler droplet energy effects on infiltration and near-surface, unsaturated hydraulic conductivity. In *Preferential Flow: Water Movement and Chemical Transport in the Environment. Proc. 2nd Intl. Symp.*, 283-286. D. D. Bosch and K. W. King, eds. St. Joseph, Mich.: ASAE.
- Lehrsch, G. A., and D. C. Kincaid. 2006. Sprinkler droplet energy effects on soil penetration resistance and aggregate stability and size distribution. *Soil Sci.* 171(6): 435-447.
- Lehrsch, G. A., D. L. Bjorneberg, and R. E. Sojka. 2005. Erosion: Irrigation-induced. In *Encyclopedia of Soils in the Environment* 1: 456-463. D. Hillel, ed. Oxford, U.K.: Elsevier.
- Lehrsch, G. A., C. W. Robbins, and M. J. Brown. 2008. Whey utilization in furrow irrigation: Effects on aggregate stability and erosion. *Bioresour. Tech.* 99(17): 8458-8463.
- Lentz, R. D., R. E. Sojka, and D. L. Carter. 1996. Furrow irrigation water-quality effects on soil loss and infiltration. *SSSA J.* 60(1): 238-245.
- Logsdon, S. D., J. L. Jordahl, and D. L. Karlen. 1993. Tillage and crop effects on ponded and tension infiltration rates. *Soil Tillage Res.* 28(2): 179-189.
- McDole, R. E., and H. B. Maxwell. 1987. Soil survey: University of Idaho Research and Extension Center and USDA Snake River Conservation Research Center. Agric. Exp. Stn. Bull. No. 656. Moscow, Idaho: University of Idaho.
- McIntyre, D. S. 1958. Permeability measurements of soil crusts formed by raindrop impact. *Soil Sci.* 85(4): 185-189.
- Messing, L., and N. J. Jarvis. 1993. Temporal variation in the hydraulic conductivity of a tilled clay soil as measured by tension infiltrometers. *J. Soil Sci.* 44(1): 11-24.
- Moret, D., and J. L. Arrué. 2007. Dynamics of soil hydraulic properties during fallow as affected by tillage. *Soil Tillage Res.* 96(1-2): 103-113.
- Murphy, B. W., T. B. Koen, B. A. Jones, and L. M. Huxedurp. 1993. Temporal variation of hydraulic properties for some soils with fragile structure. *Australian J. Soil Res.* 31(2): 179-197.
- Nelson, D. W., and L. E. Sommers. 1996. Total carbon, organic carbon, and organic matter. In *Methods of Soil Analysis: Part 3. Chemical Methods*, 961-1010. SSSA Book Series 5. D. L. Sparks, A. L. Page, P. A. Helmke, and R. H. Loeppert, eds. Madison, Wisc.: SSSA.
- Pikul, J. L., Jr., and J. F. Zuzel. 1994. Soil crusting and water infiltration affected by long-term tillage and residue management. *SSSA J.* 58(5): 1524-1530.
- Rasmussen, P. E., S. L. Albrecht, and R. W. Smiley. 1998. Soil C and N changes under tillage and cropping systems in semi-arid Pacific Northwest agriculture. *Soil Tillage Res.* 47(3-4): 197-205.
- Rasmussen, W. W., and J. W. Cary. 1979. White spots, deep tillage and water infiltration of the Portneuf and related silt loam soils. Agric. Exp. Stn. Current Information Series 460. Moscow, Idaho: University of Idaho.
- Reynolds, W. D. 2008. Unsaturated hydraulic properties: Field tension infiltrometer. In *Soil Sampling and Methods of Analysis*, 1107-1127. 2nd ed. M. R. Carter, and E. G. Gregorich, eds. Boca Raton, Fla.: CRC Press.
- Reynolds, W. D., E. G. Gregorich, and W. E. Curnoe. 1995. Characterisation of water transmission properties in tilled and untilled soils using tension infiltrometers. *Soil Tillage Res.* 33(2): 117-131.
- Robbins, C. W., and C. L. Wiegand. 1990. Field and laboratory measurements. In *Agricultural Salinity Assessment and Management*, 203-219. ASCE Man. No. 71. K. K. Tanji, ed. New York, N.Y.: ASCE.
- Robbins, C. W., B. E. Mackey, and L. L. Freeborn. 1997. Improving exposed subsoils with fertilizers and crop rotations. *SSSA J.* 61(4): 1221-1225.
- Robbins, C. W., L. L. Freeborn, and D. T. Westermann. 2000. Organic phosphorus source effects on calcareous soil

- phosphorus and organic carbon. *J. Environ. Qual.* 29(3): 973-978.
- Römkens, M. J. M., S. N. Prasad, and F. D. Whisler. 1990. Surface sealing and infiltration. In *Process Studies in Hillslope Hydrology*, 127-172. M. G. Anderson and T. P. Burt, eds. London, U.K.: John Wiley.
- Santos, F. L., J. L. Reis, O. C. Martins, N. L. Castanheira, and R. P. Serralheiro. 2003. Comparative assessment of infiltration, runoff, and erosion of sprinkler irrigated soils. *Biosyst. Eng.* 86(3): 355-364.
- SAS. 2009. *SAS Online Documentation, Version 9.2* (CD-ROM). Cary, N.C.: SAS Institute, Inc.
- Sauer, T. J., and S. D. Logsdon. 2002. Hydraulic and physical properties of stony soils in a small watershed. *SSSA J.* 66(6): 1947-1956.
- Schwartz, R. C., S. R. Evett, and P. W. Unger. 2003. Soil hydraulic properties of cropland compared with reestablished and native grassland. *Geoderma* 116(1-2): 47-60.
- Six, J., H. Bossuyt, S. Degryze, and K. Denef. 2004. A history of research on the link between (micro)aggregates, soil biota, and soil organic matter dynamics. *Soil Tillage Res.* 79(1): 7-31.
- Smettem, K. R. J. 1987. Characterization of water entry into a soil with a contrasting textural class: Spatial variability of infiltration parameters and influence of macroporosity. *Soil Sci.* 144(3): 167-174.
- Sojka, R. E., D. L. Bjorneberg, T. J. Trout, T. S. Strelkoff, and M. A. Nearing. 2007. The importance and challenge of modeling irrigation-induced erosion. *J. Soil Water Cons.* 62(3): 153-162.
- Sojka, R. E., G. A. Lehrsch, S. J. Kostka, J. L. Reed, A. C. Koehn, and J. A. Foerster. 2009. Soil water measurements relevant to agronomic and environmental functions of chemically treated soil. In *Pesticide Formulations and Delivery Systems, 28th Vol.: Global Trends and Regulatory Drivers in the Crop Protection Industry*, 117-144. Spec. Tech. Publ. STP 1507. A. M. Rohde, C. Martin, and G. Otis, eds. West Conshohocken, Pa.: ASTM.
- Somararatne, N. M., and K. R. J. Smettem. 1993. Effect of cultivation and raindrop impact on the surface hydraulic properties of an alfisol under wheat. *Soil Tillage Res.* 26(2): 115-125.
- Strudley, M. W., T. R. Green, and J. C. Ascough II. 2008. Tillage effects on soil hydraulic properties in space and time: State of the science. *Soil Tillage Res.* 99(1): 4-48.
- Thompson, A. L., and L. G. James. 1985. Water droplet impact and its effect on infiltration. *Trans. ASAE* 28(5): 1506-1510, 1520.
- Thony, J.-L., G. Vachaud, B. E. Clothier, and R. Angulo-Jaramillo. 1991. Field measurement of the hydraulic properties of soil. *Soil Tech.* 4(2): 111-123.
- Trout, T. J., and D. C. Kincaid. 1987. Infiltration research needs for irrigated agriculture. ASAE Paper No. 872538. St. Joseph, Mich.: ASAE.
- Westermann, D. T., D. L. Bjorneberg, J. K. Aase, and C. W. Robbins. 2001. Phosphorus losses in furrow irrigation runoff. *J. Environ. Qual.* 30(3): 1009-1015.
- White, I., M. J. Sully, and K. M. Perroux. 1992. Measurement of surface-soil hydraulic properties: Disk permeameters, tension infiltrometers, and other techniques. In *Advances in Measurement of Soil Physical Properties: Bringing Theory into Practice*, 69-103. Spec. Publ. 30. G. C. Topp, W. D. Reynolds, and R. E. Green, eds. Madison, Wisc.: SSSA.
- Wuest, S. B., T. C. Caesar-TonThat, S. F. Wright, and J. D. Williams. 2005. Organic matter addition, N, and residue burning effects on infiltration, biological, and physical properties of an intensively tilled silt-loam soil. *Soil Tillage Res.* 84(2): 154-167.
- Yonts, C. D., and K. L. Palm. 2001. Irrigation management. In *Sugarbeet Production Guide*, 161-178. Coop. Ext. Bull. EC01-156. R. G. Wilson, ed. Lincoln, Neb.: University of Nebraska.